



---

## Installation Guide for 10 GigaBit Optical Bypass Switch





## Contents

Introduction . . . . .	1
Key Features . . . . .	2
About This Guide . . . . .	2
Product Diagrams . . . . .	3
Power Loss Bypass . . . . .	4
Unpacking and Inspection . . . . .	5
Connecting to the Network . . . . .	6
Connecting to the In-line Security Device . . . . .	7
Specifications . . . . .	8
Limitations on Warranty and Liability . . . . .	9

---

**PLEASE READ THESE LEGAL NOTICES CAREFULLY.**

By using a Net Optics Optical Bypass Switch you agree to the terms and conditions of usage set forth by Net Optics, Inc.

No licenses, express or implied, are granted with respect to any of the technology described in this manual. Net Optics retains all intellectual property rights associated with the technology described in this manual. This manual is intended to assist with installing Net Optics products into your network.

***Trademarks and Copyrights***

© 2007 by Net Optics, Inc. Net Optics® is a registered trademark of Net Optics, Inc. Additional company and product names may be trademarks or registered trademarks of the individual companies and are respectfully acknowledged.

***Additional Information***

Net Optics, Inc. reserves the right to make changes in specifications and other information contained in this document without prior notice. Every effort has been made to ensure that the information in this document is accurate.

---

## **Introduction**

Net Optics 10 GigaBit Optical Bypass Switches provide a permanent and trouble-free access port for in-line network security and monitoring devices. The Optical Bypass Switch automatically switches network traffic through added in-line devices or bypasses devices that are about to be removed. Prevent link failure when attached IPS and IDS devices lose power by powering the Bypass Switch and in-line device from the same power source.

### **Uninterrupted Traffic**

The Optical Bypass Switch supports fail-open monitoring with any 10 Giga-Bit fiber in-line device when it shares the same power source as the in-line appliance. While the Optical Bypass Switch is receiving power, it diverts network traffic to attached in-line devices. In this state, all in-line traffic is routed directly to the device connected to the Optical Bypass Switch.

When the Optical Bypass Switch loses power, in-line traffic continues to flow through the network link, but is no longer routed through the device. This allows the network devices to be removed and replaced without network downtime. Once power is restored to the Optical Bypass Switch, network traffic is seamlessly diverted to the in-line device, allowing it to resume its critical functions.

### **Simply Plug It In**

Each Bypass Switch includes all the cables and power supplies you need to quickly connect to an IPS. Three quick steps is all it takes to establish a secure connection point for in-line devices.

## Key Features

### Passive, Secure Technology

- Fail-safe monitoring with any 10 GigaBit fiber in-line appliance at speeds of 10 Gbps
- Increased reliability on critical network links
- High-speed optical switching with minimal insertion loss
- Fully RoHS compliant

### Ease of Use

- LED indicator shows power status
- Front-mounted connectors support easy installation and operation
- Cables included for plug-and-play deployment
- Silk-screened application diagram illustrates all connections for easy deployment
- Optional 19-inch rack frames holds two Bypass Switches
- Compatible with all major manufacturers' monitoring devices, including protocol analyzers, probes, and intrusion detection/prevention systems

### Support

- Net Optics offers free technical support throughout the lifetime of your purchase. Our technical support team is available from 8 am to 5 pm Pacific Time, Monday through Friday at +1 (408) 737-7777 and via email at [ts-support@netoptics.com](mailto:ts-support@netoptics.com). FAQs are also available on Net Optics website at [www.netoptics.com](http://www.netoptics.com).

## About This Guide

Please read the guide before attempting to install 10 GigaBit Bypass Switch. This guide covers the following models:

Part Number	Description
BPO-SR	10 GB SR Bypass Switch
BPO-50SR	10 GB SR Bypass Switch, 50um
BPO-LR	10 GB LR Bypass Switch

### Product Diagrams

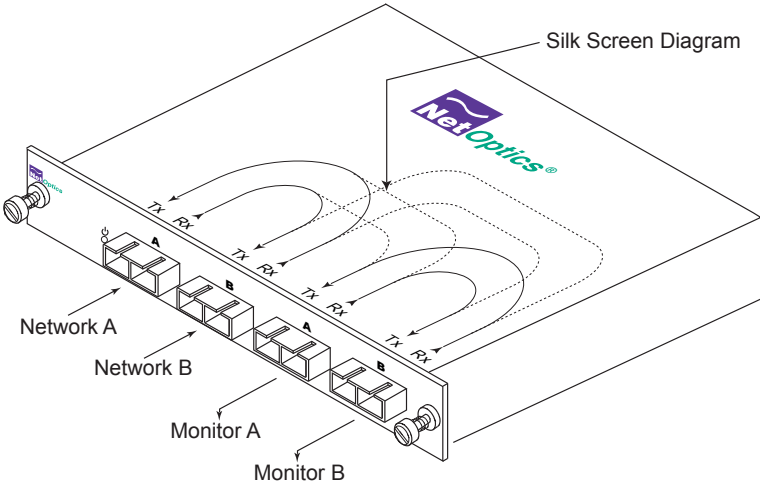

**Figure 1: BPO-50SR Connectors and Application Diagram**

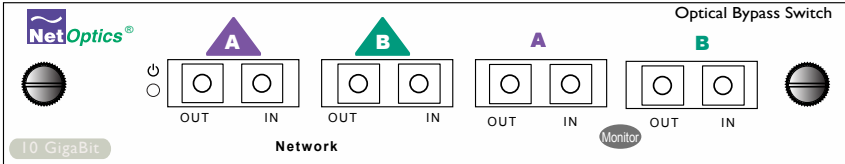

**Figure 2: Front Panel**

### Power Loss Bypass

The Optical Bypass Switch protects link integrity when the in-line appliance loses power. When the Bypass Switch is receiving power it is in Bypass Disabled (OFF) mode. In Bypass Disabled mode the switch sends network traffic through the connected device.

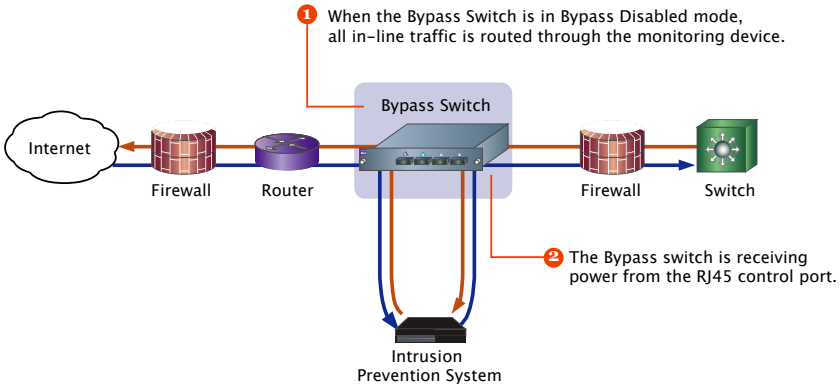

**Figure 3: Bypass Disabled Mode**

When power to switch fails, it enters Bypass Enabled (ON) mode and network traffic bypasses the connected device until power to the switch is restored.

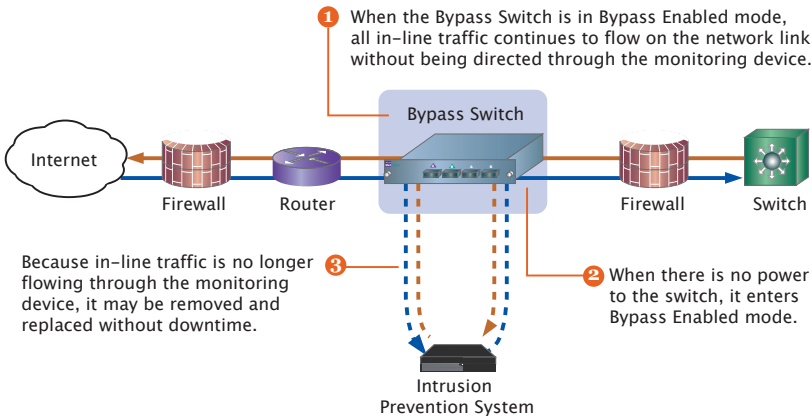

**Figure 4: Bypass Enabled Mode**

## **Unpacking and Inspection**

Unpack the Optical Bypass Switch, power supply, and cables provided. Each Optical Bypass Switch is delivered with the following:

- 1 Power supply and cable
- 2 Duplex SC fiber cables
- 1 Manual

You may have also ordered an extended warranty. Carefully check the packing slip against parts received. If any component is missing or damaged, contact Net Optics Customer Service immediately.

### Connecting to the Network

1. Connect Network Port A to the appropriate switch, server or router device.
2. Connect Network Port B to the appropriate switch, server or router device.
3. Verify that the Bypass Switch Network Ports are cabled in-line between two devices.

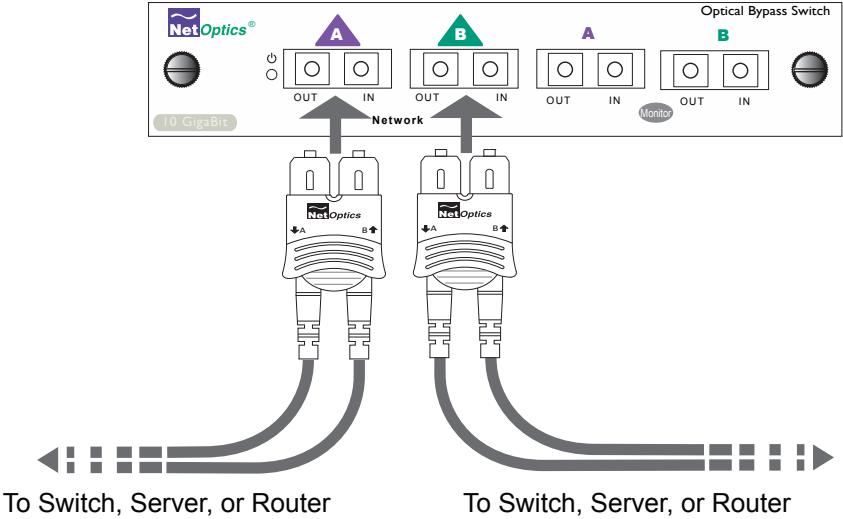

**Figure 6:** Connecting to the Network

### Connecting to the In-line Security Device

1. Connect Monitoring Port A to the in-line appliance using a duplex SC fiber cable.
2. Connect Monitoring Port B to the the in-line appliance using a duplex SC fiber cable.
4. Connect power to the Bypass Switch and to a power source on the in-line device or other shared power source.
3. Verify that the in-line device is receiving traffic from the Bypass Switch.

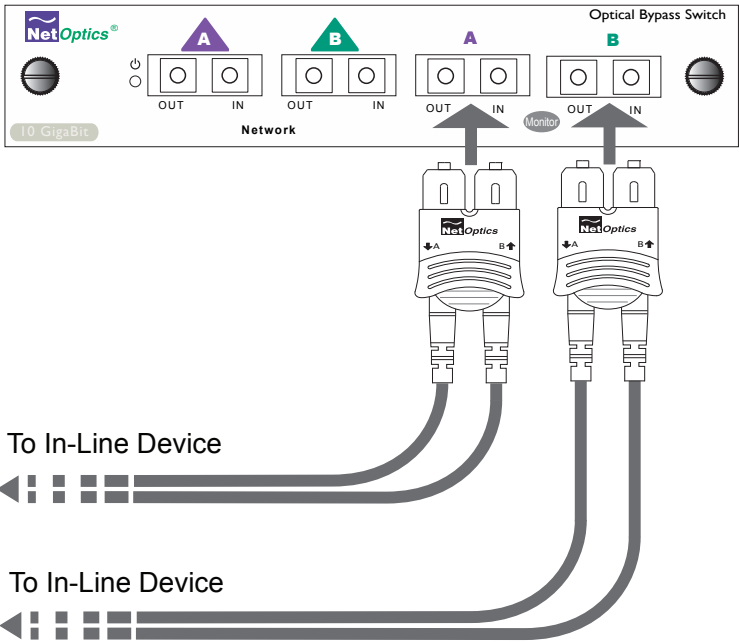

**Figure 7: Connecting to the In-line Device**

## Specifications

### Optical Interface

#### Laser Class

Class I, eye-safe, laser emitter type. These Class I Lasers conform to the applicable requirements per US 21 CFR (J) and EN 60825-1, also UL 1950 applications.

#### Fiber Type

Multimode Corning 50 or 62.5 /125 $\mu$ m, wavelength 850nm

Singlemode Corning 8.5 /125 $\mu$ m, wavelength 1310nm

### Environment

Operating Temperature: 0°C to 40°C

Storage Temperature: -10°C to 70°C

Relative Humidity: 10% min, 95% max, non-condensing

### Power

Supply Input Power: 100-250V, 0.5A, 47-63Hz

Supply Output Power: 5V, 2.4A

### Mechanical

Dimensions: 1.125" high x 6.0" deep x 6.5" wide

### Connectors

(2) Duplex SC connectors (monitor ports)

(2) Duplex SC connectors (network ports)

### Certifications

Fully RoHS compliant

## Limitations on Warranty and Liability

Net Optics offers a limited warranty for all its products. IN NO EVENT SHALL NET OPTICS, INC. BE LIABLE FOR ANY DAMAGES INCURRED BY THE USE OF THE PRODUCTS (INCLUDING BOTH HARDWARE AND SOFTWARE) DESCRIBED IN THIS MANUAL, OR BY ANY DEFECT OR INACCURACY IN THIS MANUAL ITSELF. THIS INCLUDES BUT IS NOT LIMITED TO LOST PROFITS, LOST SAVINGS, AND ANY INCIDENTAL OR CONSEQUENTIAL DAMAGES ARISING FROM THE USE OR INABILITY TO USE THIS PRODUCT, even if Net Optics has been advised of the possibility of such damages. Some states do not allow the exclusion or limitation of implied warranties or liability for incidental or consequential damages, so the above limitation or exclusion may not apply to you.

Net Optics, Inc. warrants this Optical Bypass Switch to be in good working order for a period of ONE YEAR from the date of purchase from Net Optics or an authorized Net Optics reseller.

Should the unit fail anytime during the said ONE YEAR period, Net Optics will, at its discretion, repair or replace the product. This warranty is limited to defects in workmanship and materials and does not cover damage from accident, disaster, misuse, abuse or unauthorized modifications.

If you have a problem and require service, please call the number listed at the end of this section and speak with our technical service personnel. They may provide you with an RMA number, which must accompany any returned product. Return the product in its original shipping container (or equivalent) insured and with proof of purchase.

### *Additional Information*

Net Optics, Inc. reserves the right to make changes in specifications and other information contained in this document without prior notice. Every effort has been made to ensure that the information in this document is accurate. Net Optics is not responsible for typographical errors.

THE WARRANTY AND REMEDIES SET FORTH ABOVE ARE EXCLUSIVE AND IN LIEU OF ALL OTHERS, EXPRESS OR IMPLIED. No Net Optics reseller, agent, or employee is authorized to make any modification, extension, or addition to this warranty.

Net Optics is always open to any comments or suggestions you may have about its products and/or this manual.

Send correspondence to  
Net Optics, Inc.  
5303 Betsy Ross Drive  
Santa Clara, CA 95054 USA  
Telephone: +1 (408) 737-7777  
Fax: +1 (408) 745-7719  
Email: [info@netoptics.com](mailto:info@netoptics.com)/Internet: [www.netoptics.com](http://www.netoptics.com)

All Rights Reserved. Printed in the U.S.A. No part of this publication may be reproduced, transmitted, transcribed, stored in a retrieval system, or translated into any language or computer language, in any form, by any means, without prior written consent of Net Optics, Inc., with the following exceptions: Any person is authorized to store documentation on a single computer for personal use only and that the documentation contains Net Optics' copyright notice.





**[www.netoptics.com](http://www.netoptics.com)**