

GigaBit SX Port Aggregator Tap Memory Operation

State 1: Side A + Side B is less than or equal to 100% of the NIC's receive capacity.

Example: On a 1000 Mbps link, Side A is at 300 Mbps and Side B is at 500 Mbps. The NIC receives 800 Mbps of traffic (80% utilization), so no memory is required for the monitoring device NIC to process all full-duplex traffic.

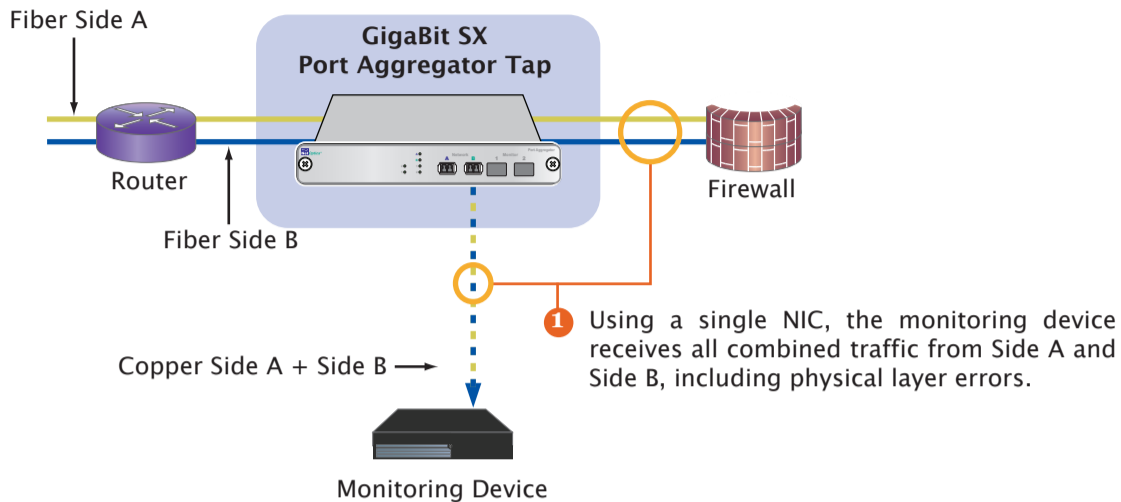

State 2: Side A + Side B becomes greater than 100% of the NIC's receive capacity.

Example: There is a burst of traffic, so Side A is now at 900 Mbps, while Side B remains at 500 Mbps. The NIC's utilization is at 140%, requiring the use of memory to help prevent data loss.

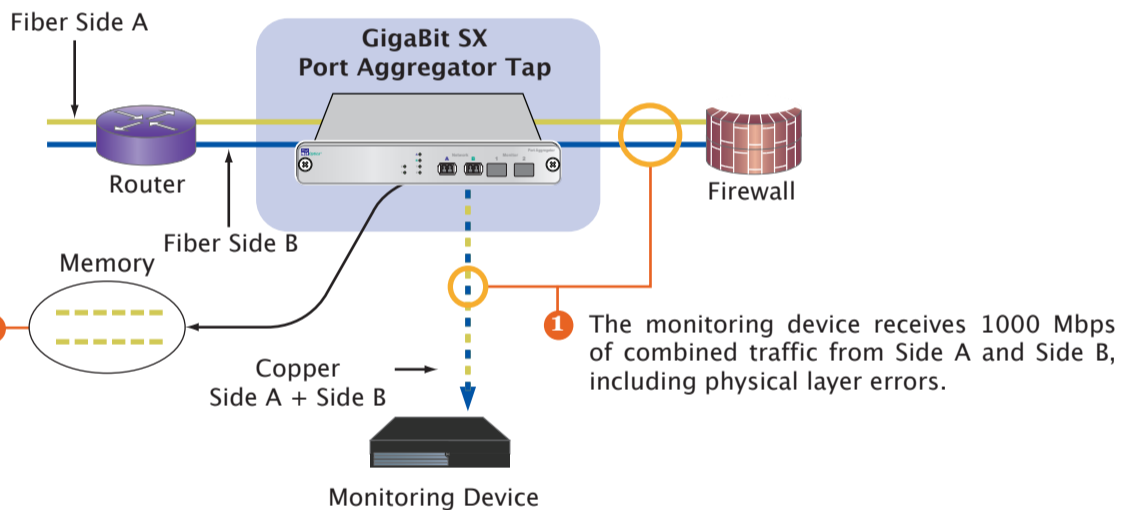

State 3: Side A + Side B is once again less than 100% of the NIC's receive capacity.

Example: On a 100 Mbps link, Side A is again at 30 Mbps and Side B remains at 50 Mbps. The NIC's utilization is again at 80%.

