



Installation Guide for 4 Station Bypass Switch with Heartbeat™



Contents

Introduction	1
Key Features	2
About this Guide	2
Product Diagrams	3
Bypass Modes	4
Heartbeat Bypass	5
Unpacking and Inspection	6
Configuring the Bypass Switch	6
Connecting to the Network	11
Connecting to the In-line Device	12
Specifications	13
Limitations on Warranty and Liability	14

PLEASE READ THESE LEGAL NOTICES CAREFULLY.

By using a Net Optics Optical Bypass Switch you agree to the terms and conditions of usage set forth by Net Optics, Inc.

No licenses, express or implied, are granted with respect to any of the technology described in this manual. Net Optics retains all intellectual property rights associated with the technology described in this manual. This manual is intended to assist with installing Net Optics products into your network.

Trademarks and Copyrights

© 2007 by Net Optics, Inc. Net Optics® is a registered trademark of Net Optics, Inc. Additional company and product names may be trademarks or registered trademarks of the individual companies and are respectfully acknowledged.

Additional Information

Net Optics, Inc. reserves the right to make changes in specifications and other information contained in this document without prior notice. Every effort has been made to ensure that the information in this document is accurate.

Introduction

Thank you for choosing the most versatile Bypass Switch available today. Whether you are a novice or an expert, this installation guide is designed to help answer any questions and provide a quick set-up reference.

Net Optics 4 Station Bypass Switches with Heartbeat provide a permanent and trouble-free access port for up to four in-line network security and monitoring segments. These Bypass Switches automatically switch network traffic through added in-line devices or bypass devices that are about to be removed. With the heartbeat technology, the 4 Station Bypass Switch protects up to four network traffic links independently against signal loss, power loss and application failure to the attached in-line devices.

Link Fault Protection

The 4 Station Bypass Switch with Heartbeat monitors the attached in-line device by sending a heartbeat packet to the device. If each Bypass Switch does not receive the heartbeat back, it automatically switches network traffic to bypass the unresponsive device—even if the device is still receiving power. Each Bypass continues to send the heartbeat and restores the traffic through the in-line device as soon as the link is restored.

Uninterrupted Traffic

The 4 Station Bypass Switch supports fail-open monitoring with any in-line device when it shares the same power source as the in-line appliance. For as long as the Bypass Switch is receiving power, it diverts network traffic to attached in-line devices. In this state, all in-line traffic is routed directly to the devices connected to the 4 Station Bypass Switch segment.

When the 4 Station Bypass Switch loses power, in-line traffic continues to flow through the network links, but is no longer routed through the devices. This allows the in-line devices to be removed and replaced without network downtime. Once power is restored to the Bypass Switch, network traffic is seamlessly diverted to the in-line devices, allowing it to resume their critical functions.

Three Simple Steps

Three quick steps is all it takes to establish a secure connection point for inline devices. For special applications, customize the bypass trigger and Heartbeat rate from an RS232 command line interface.

Key Features

Passive, Secure Technology

- Fail-open monitoring with any Gigabit fiber or 10/100/1000 Mbps in-line appliance depending on the model purchased
- Protects against power, link, and application failure
- Increased reliability on critical network links
- High-speed optical switching with minimal insertion loss
- Custom Heartbeat packet option
- Four individually segmented Bypass Switches for greater flexibility
- Fully RoHS Compliant

Ease of Use

- LED indicators show power, speed, link, and activity status
- Front-mounted connectors support easy installation and operation
- Compatible with all major manufacturers’ monitoring devices, including protocol analyzers, probes, and intrusion detection/prevention systems

Support

- Our technical support team is available from 8 am to 5 pm Pacific Time, Monday through Friday at +1 (408) 737-7777 and via email at ts-support@netoptics.com. FAQs are also available on at: www.netoptics.com/support/FAQ

About this Guide

Part Number	Description
BP4-HBCU3	10/100/1000 4 Station Bypass Switch with Heartbeat
BPO4-HBSX-LC	GigaBit SX 4 Station Bypass Switch with Heartbeat
BPO4-HBLX-LC	GigaBit LX 4 Station Bypass Switch with Heartbeat
BPC4-HB2CU3/2SX	(2) GigaBit SX and (2) 10/100/1000 4 Station Bypass Switch with Heartbeat
BPC4-HB2CU3/2LX	(2) GigaBit LX and (2) 10/100/1000 4 Station Bypass Switch with Heartbeat
BPO4-HB2SX/2LX	(2) GigaBit SX and (2) GigaBit LX 4 Station Bypass Switch with Heartbeat
BPC4-HB2CU3/250SX	(2) GigaBit SX 50um and (2) 10/100/1000 4 Station Bypass Switch with Heartbeat
BPO4-HB250SX/2LX	(2) GigaBit SX 50um and (2) GigaBit LX 4 Station Bypass Switch with Heartbeat
BPO4-HB50SX-LC	GigaBit SX 50um 4 Station Bypass Switch with Heartbeat

Product Diagrams



Figure 1: Front View (BP4-HBCU3)



Figure 2: Front View (BPO4-HBSX-LC, BPO4-HBLX-LC and BPO4-HB2SX/2LX)



Figure 3: Front View (BPC4-HB2CU3/2SX and BPC4-HB2CU3/2LX)



Figure 4: Rear View (All Models)

Bypass Modes

The 4 Station Bypass Switch with Heartbeat bypasses the attached in-line device when one of three events occurs:

- Power loss
- Link failure to the Switch segment
- Application failure to the Switch segment

Two LEDs on the front of a Bypass Switch segment indicate whether the switch is bypassing the connected appliance or not. When the Bypass ON indicator is illuminated, the bypass switch has not received the heartbeat packet as expected and is in Bypass Enabled mode. When the Bypass OFF indicator is illuminated, the bypass switch is in Bypass Disabled mode and is sending traffic through the attached in-line device. When the switch is in Bypass Enabled (ON) mode, the switch circuitry re-directs network traffic around the in-line appliance. In Bypass Enabled mode Network Ports A and B are connected (see Figure 4).

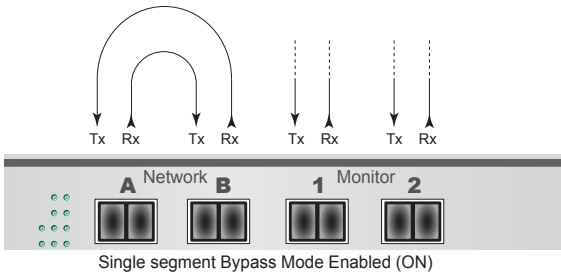

Figure 5: Bypass Enabled

When the switch is in Bypass Disabled (OFF) mode, the switch circuitry sends network traffic through the in-line appliance. In Bypass Disabled mode, Network Port A is connected to Monitor Port 1 and Network Port 2 is connected to Monitor Port B (see Figure 5).

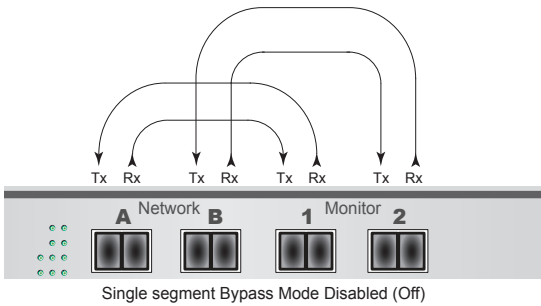

Figure 6: Bypass Disabled

Heartbeat Bypass per Segment

The 4 Station Bypass Switch with Heartbeat protects against both physical link failure and application failure on the in-line appliance. The switch checks the path through the in-line appliance by sending a packet every second from Monitor Port 1. The bypass switch validates the path when it receives the packet on the Monitor Port 2. If the bypass switch does not receive the packet as expected three times in a row, the bypass switch automatically enters Bypass Enabled (ON) mode. You can change the number of the heartbeat packets required before the bypass switch enters Bypass Enabled mode from the CLI (see *Configuring the Bypass Switch* on page 6).

Below is the default IPX heartbeat packet sent once every second from the Monitor Port 1. You can change the default timing of the heartbeat packet and the heartbeat packet from the CLI (see *Configuring the Bypass Switch* on page 6).

Packet Contents (Hex)	Description
-----	-----
00 50 C2 3C 60 00	MAC DA Net Optics
00 50 C2 3C 60 01	MAC SA Net Optics
81 37	Packet Type IPX
FF FF 00 30 00 00 00 00	
40 04 EC A2 C6 13 01 02	
C6 13 01 01 00 00 00 00	
00 00 00 00 00 00 00 00	
00 00 00 00 00 00 00 00	
00 00 00 00 00 00 00 00	
82 A2 BA 71	CRC

The switch continues to send the heartbeat packet and will return to Bypass Disabled mode when it receives three consecutive packets on Monitor Port D.

Unpacking and Inspection

Unpack the 4 Station Bypass Switch and power supplies provided.

Each 4 Station Bypass Switch is delivered with the following:

- 2 Power supplies
- DB-9 RS232 cables
- 1 Manual

You may have also purchased an extended warranty. If any component is missing or damaged, contact Net Optics Technical Support immediately.

Configuring the Bypass Switch

This Bypass Switch allows you to set several configuration options and to display configuration information. You can set:

The frequency of the heartbeat.

This defines the period of time that passes before the switch considers the packet to have timed out. The default is 1 second.

The number of timeouts allowed.

This is the number of packets missed before the switch bypasses the IPS (retry count). The default is 3 missed packets.

Port communication parameters.

You can turn Link Fault Detect and Bypass Detect on or off. The default is LFD and Bypass Detect off.

A custom heartbeat packet.

You can input a custom heartbeat packet to suit special needs. The default is the IPX packet shown on page 5.

Fail Mode:

Fail Open - when in Bypass state, data is routed from Port A to B
Fail Closed - when in Bypass state, ports A and B are shut down

Reset to factory defaults.

Use this option to quickly restore the original configuration.

For quick reference, you can display the configuration settings and heartbeat packet.

Link Fault Detect

You can set the bypass switch to drop the remaining full-duplex link when one side fails. The Link Fault Detect feature ensures that connected devices are aware of a failure on both sides of the link.

Bypass Detect

You can set the Monitor Ports to cycle on and off while the bypass switch is in Bypass Enabled mode. In Bypass Detect mode, the Monitor Ports cycle through five seconds off followed by fifteen seconds on. The alternating link status can be used to trigger attached devices to send an alarm to a management system every time the bypass switch turns off the Monitor Ports. When the bypass switch returns to Bypass Disabled mode, the Monitor Ports remain on and the on/off cycle is discontinued.

Note:

All of the following instructions on pages 7-10 will need to be completed for each segment of the 4 Station Bypass Switch. Before starting, make sure power to the bypass switch is disconnected.

To access a bypass switch segment using CLI:

1. Using the RS232 DB-9 cable provided, connect a PC running terminal emulation software, such as HyperTerminal to the RS232 port on the rear panel of the bypass switch.
2. Set the terminal emulation software to the following communication parameters:
 - 9600 baud
 - 8 data bit
 - No parity
 - 1 stop bit
 - No flow control
3. Connect power to the bypass switch. The software compile date and time is displayed in the terminal emulation software as shown in the example below.

Compiled on 16-Jan-06 15:35:00

4. Type ? and press ENTER for a list of commands.

The following commands are listed:

a = Set Timeouts
b = Set Configuration
c = Set Heartbeat Packet
d = Show Configuration
e = Show Heartbeat Packet
f = Show Port Status
g = Set Switch Name
z = Reset to Factory Defaults

To set the timeout values:

1. Type a and press Enter to set the timeout values.
2. At the input time out period prompt, enter the number of seconds between each heartbeat (1-254 seconds). Press Enter.
3. At the input retry count prompt, enter the number of missed heartbeats allowed before the switch enters Bypass ON mode (1-254). The input retry count must be greater than or equal to the input timeout. Press Enter.

Note:

Manufacturing default for Input Timeout Period and Input Retry Count are set to 1 and 3 respectively.

To set the LFD and Bypass Detect options:

1. Type b and press Enter.
2. At the Bypass Detect on/off prompt, type **1** to turn on or **0** to turn off Bypass Detect.
3. At the LFD on/off prompt, type **1** to turn on or **0** to turn off Link Fault Detect.

To input a custom heartbeat packet:

1. Type c and press Enter. You are prompted for the length of the packet including header bytes and CRC bytes.

2. Enter the length of your custom packet in decimal format and press Enter. You are prompted for each packet byte.
3. Enter packet bytes in Hex format in the following order:

Note:

The first 3 bytes of the Heartbeat Packet are fixed.

- MAC DA Net Optics (6 bytes)
- MAC SA Net Optics (6 bytes)
- Packet Type (2 bytes)
- Packet Bytes
- CRC (4 bytes)

Alternately you can load the packet as a pre-formatted text file. The text file should be one byte per line, beginning with a decimal value for the number of packets followed by hex values for the remaining bytes. Load the text file at the packet length prompt.

To load a custom packet from byte-by-byte or from a file, you must set the Line Delay to 1000 milliseconds and the Character Delay to 100 milliseconds in your terminal emulation software. If you are using HyperTerminal, these settings are located in the ASCII Setup dialog box found in File>Properties>Settings>ASCII Setup.

To display the current values:

1. Type d and press Enter. A list similar to the following appears.

```

Auto Negotiate      on or off
1000 Mbps           on or off
100 Mbps            on or off
10 Mbps             on or off
Duplex               half or full
LFD
Bypass Detect
Failmode
Time-out Period
Retry Count
Bypass State        on or off
Bypass Disabled
    
```

To display the current packet:

1. Type e and press Enter. The packet is displayed as shown in the example below.

```
packet length = 78
MAC DA 00 50 c2 3c 60 00
MAC SA 00 50 c2 3c 60 01
Packet Type 08 00
45 00 00 3c 18 d2 00 00
80 01 0a ff 0a 02 01 dc
0a 01 01 12 08 00 37 5c
02 00 14 00 61 62 63 64
65 66 67 68 69 6a 6b 6c
6d 6e 6f 70 71 72 73 74
75 76 77 61 62 63 64 65
66 67 68 69
CRC bb 8e 1c a9
```

To show port status:

1. Type f and press Enter. Port status for the device is displayed.

```
Port A Link
Port B Link
Port C Link
Port D Link
```

To set the Bypass Switch name:

1. Type g and press Enter.
Input 8 Char name :
2. Give the Bypass Switch a name and press Enter

To restore the bypass switch to factory defaults:

1. Type z and press Enter. You are prompted to select which type of packet you want to restore, IP or IPX.
2. Select 1 to restore defaults with an IP packet or 0 to restore defaults with an IPX packet.

The bypass switch will be reset to the following defaults:

- Input Timeout Period: 1
- Input Retry Count: 3
- LFD: On
- Bypass Detect: On
- Heartbeat Packet: IPX or IP (dependent on selection made in step 2)

Connecting to the Network

To connect a bypass switch segment to the network:

1. Connect Network Port A to the appropriate switch, server or router device. This acts as your DCE interface.
2. Connect Network Port B to the appropriate switch, server or router device. This acts as your DTE interface.

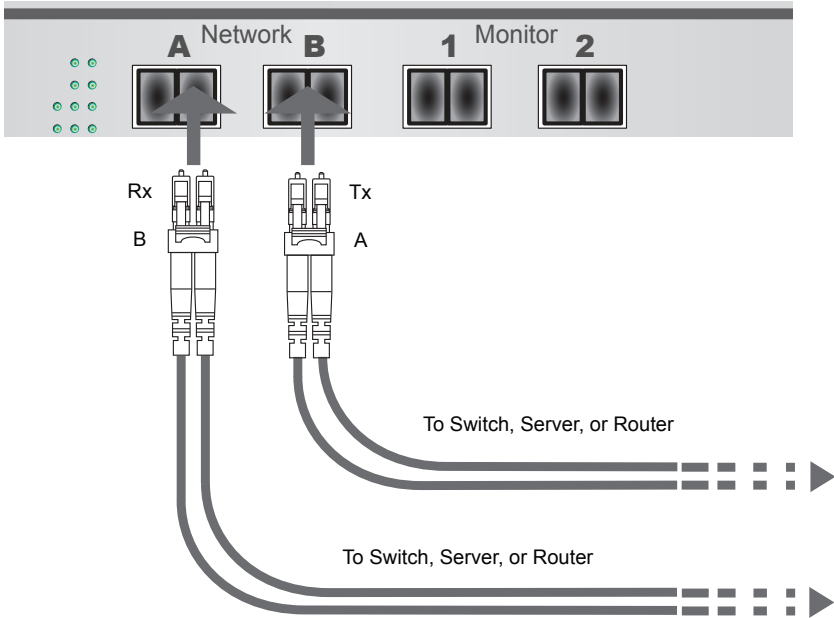

Figure 7: Connecting one Bypass Switch segment to the Network

3. Verify that the bypass switch Network Ports are cabled in-line between two devices.
4. Repeat steps 1-3 for the remaining segments.

Connecting to the Monitoring Device

To connect a bypass switch segment to the in-line device:

1. Connect Monitoring Port 1 to the appropriate in-line appliance. This acts as your DCE interface.
2. Connect Monitoring Port 2 to the appropriate in-line appliance. This acts as your DTE interface.

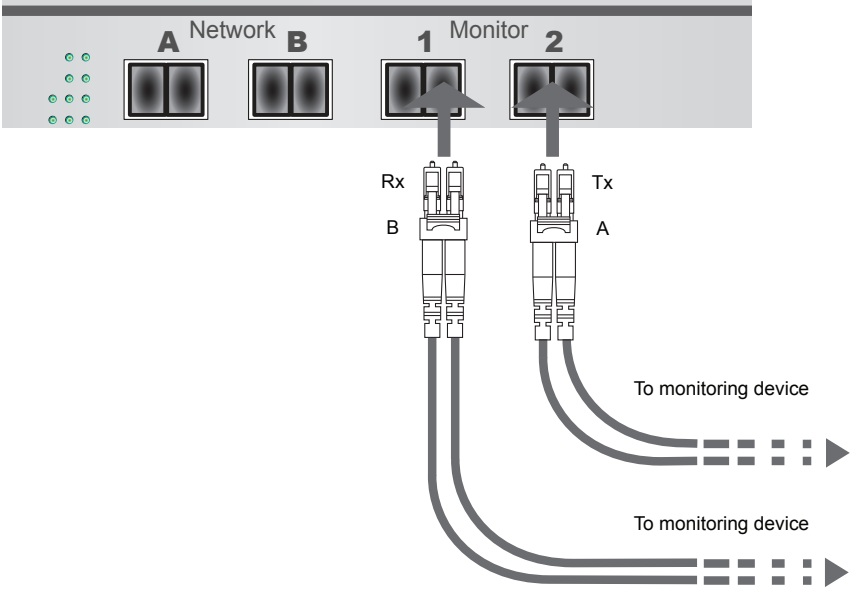

Figure 8: Connecting one Bypass Switch segment to the Monitoring Device

3. Verify that the bypass switch Monitoring Ports are cabled in-line to the attached device.
4. Repeat steps 1-3 for the remaining segments.
5. Connect power to the switch. If you are implementing power fault failover, make sure you connect the switches' power supplies to the same power sources that the IPS is using.

Specifications

Copper Interface

Cable Type: 22-24 AWG unshielded twisted pair cable, CAT5/CAT5e
Link Distance Supported: 100 meters

Optical Interface

Fiber Type: Multimode: Corning 50 or 62.5/125 μ m, wavelength, 850nm
Fiber Type: Singlemode: Corning 8.5/125 μ m, wavelength, 1310nm

Note:

There is no insertion loss when the bypass switch is not receiving power.

Environmental

Operating Temperature: 5°C to 40°C
Storage Temperature: -10°C to 70°C
Relative Humidity: 10% min, 95% max, non-condensing

Power

Power Supply: Input Power: 100-240V, 0.5A, 47-63Hz
Output Power: 12V, 7A

Mechanical

Dimensions: 1.75" high x 11.5" deep x 17" wide

Connectors (Depending on model purchased)

Duplex LC connectors (monitoring ports)
Duplex LC connectors (network ports)
RJ45 connectors (monitoring ports)
RJ45 connectors (network ports)
DB9 RS232 connectors (management ports)

Certifications

Fully RoHS Compliant

Limitations on Warranty and Liability

Net Optics offers a limited warranty for all its products. IN NO EVENT SHALL NET OPTICS, INC. BE LIABLE FOR ANY DAMAGES INCURRED BY THE USE OF THE PRODUCTS (INCLUDING BOTH HARDWARE AND SOFTWARE) DESCRIBED IN THIS MANUAL, OR BY ANY DEFECT OR INACCURACY IN THIS MANUAL ITSELF. THIS INCLUDES BUT IS NOT LIMITED TO LOST PROFITS, LOST SAVINGS, AND ANY INCIDENTAL OR CONSEQUENTIAL DAMAGES ARISING FROM THE USE OR INABILITY TO USE THIS PRODUCT, even if Net Optics has been advised of the possibility of such damages. Some states do not allow the exclusion or limitation of implied warranties or liability for incidental or consequential damages, so the above limitation or exclusion may not apply to you.

Net Optics, Inc. warrants this Optical Bypass Switch to be in good working order for a period of ONE YEAR from the date of purchase from Net Optics or an authorized Net Optics reseller.

Should the unit fail anytime during the said ONE YEAR period, Net Optics will, at its discretion, repair or replace the product. This warranty is limited to defects in workmanship and materials and does not cover damage from accident, disaster, misuse, abuse or unauthorized modifications.

If you have a problem and require service, please call 1-888-447-4861 to speak with a technical support representative. They may provide you with an RMA number, which must accompany any returned product. Return the product in its original shipping container (or equivalent) insured and with proof of purchase.

Additional Information

Net Optics, Inc. reserves the right to make changes in specifications and other information contained in this document without prior notice. Every effort has been made to ensure that the information in this document is accurate. Net Optics is not responsible for typographical errors.

THE WARRANTY AND REMEDIES SET FORTH ABOVE ARE EXCLUSIVE AND IN LIEU OF ALL OTHERS, EXPRESS OR IMPLIED. No Net Optics reseller, agent, or employee is authorized to make any modification, extension, or addition to this warranty.

Net Optics is always open to any comments or suggestions you may have about its products and/or this manual.

Send correspondence to
Net Optics, Inc.
5303 Betsy Ross Drive
Santa Clara, CA 95054 USA
Telephone: +1 (408) 737-7777
Fax: +1 (408) 745-7719
Email: info@netoptics.com/Internet: www.netoptics.com

All Rights Reserved. Printed in the U.S.A. No part of this publication may be reproduced, transmitted, transcribed, stored in a retrieval system, or translated into any language or computer language, in any form, by any means, without prior written consent of Net Optics, Inc., with the following exceptions: Any person is authorized to store documentation on a single computer for personal use only and that the documentation contains Net Optics' copyright notice.

www.netoptics.com