

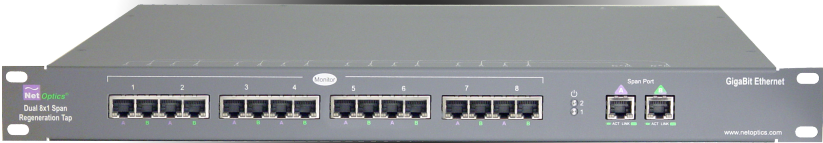

Installation Guide for GigaBit Copper Span Regeneration Tap



Contents

Introduction	1
Product Diagrams	3
LED Indicators	4
Unpacking and Inspection	5
About this Guide	5
Connecting to the Span Ports	6
Connecting to the Monitoring Devices	7
Specifications	8

PLEASE READ THESE LEGAL NOTICES CAREFULLY.

By using a Net Optics Regeneration Tap you agree to the terms and conditions of usage set forth by Net Optics, Inc.

No licenses, express or implied, are granted with respect to any of the technology described in this manual. Net Optics retains all intellectual property rights associated with the technology described in this manual. This manual is intended to assist with installing Net Optics products into your network.

Trademarks and Copyrights

© 2007 by Net Optics, Inc. Net Optics® is a registered trademark of Net Optics, Inc. Additional company and product names may be trademarks or registered trademarks of the individual companies and are respectfully acknowledged.

Additional Information

Net Optics, Inc. reserves the right to make changes in specifications and other information contained in this document without prior notice. Every effort has been made to ensure that the information in this document is accurate.

Introduction

Net Optics GigaBit Copper Span Regeneration Taps solve the key physical layer challenges of access to scarce spanning resources. For a complete picture of network health, these Taps connect two switch Span ports to up to sixteen different network management and security devices. Each Span session can be independently monitored by up to eight devices.

One Tap, No Idle Resources

Keep your intrusion detection and prevention systems, protocol analyzers, RMON probes, and other security devices productive with a single Regeneration Tap. Maximize resources and save on access points when multiple devices can monitor link traffic simultaneously through a single Regeneration Tap. Secure, passive access for multiple devices simply means a better return on monitoring investments.

Span Port Sharing

When a Span session is connected into the Network A port, this data can be monitored simultaneously on all Monitor A ports. A second span session can be monitored simultaneously on all Monitor B ports. The data on the Network A and Network B ports remains completely separate. Each monitoring device receives the same traffic in real time, providing a detailed picture of network health.

Security and Visibility

Without an IP address, monitoring devices are isolated from the network, dramatically reducing their exposure to attacks. However, the monitoring device connected to the Tap still sees all full-duplex traffic as if it were in-line.

Reliability

For extra uptime protection, Net Optics Taps offer redundant power connections. Should the primary power source fail, the Tap automatically switches to the backup power source. Power LEDs on the front of the Tap indicate the current power.

Key Features

Passive, Secure Technology

- Enables real-time, simultaneous monitoring of each 1000 Mbps span session, with up to eight monitoring devices per Span session
- Supports monitoring of all traffic forwarded by network switch span ports, including VLANs
- No IP address is needed for the Tap or monitoring device, enhancing monitoring security
- Redundant power ensures monitoring uptime
- Fully RoHS compliant

Ease of Use

- LED indicators show redundant power, speed, link, and activity status
- Front-mounted connectors support easy installation and operation
- Silk-screened application diagram illustrates all connections for easy deployment
- Tested and compatible with all major manufacturers' monitoring devices, including protocol analyzers, probes, and intrusion detection/prevention systems

Support

- Net Optics offers free technical support throughout the lifetime of your purchase. Our technical support team is available from 8 am to 5 pm Pacific Time, Monday through Friday at +1 (408) 737-7777 and via email at ts-support@netoptics.com. FAQs are also available on Net Optics website at www.netoptics.com.

Product Diagrams

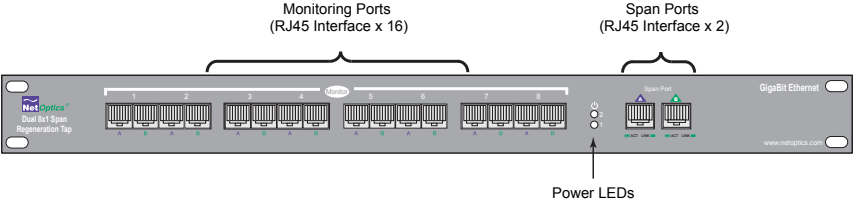

Figure 1: RGND-GCU-S8 Front Panel

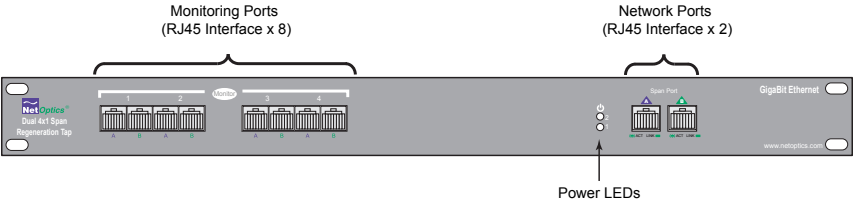

Figure 2: RGND-GCU-S4 Front Panel



Figure 3: RGND-GCU-S2 Front Panel

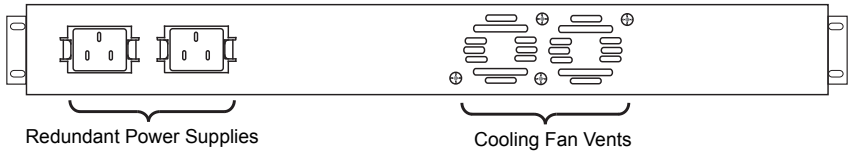

Figure 4: Back Panel (all models)

LED Indicators

Link Indicators: Located on the lower right corner of each RJ45. If a good link is established, the LED illuminates a steady green.

Activity Indicators: Located on the lower left corner of each RJ45. If there is current activity on this link, the LED flashes green.

PWR 1/ PWR 2: Main and Redundant Power. If the Tap is deployed with both power supplies, both LEDs illuminate green when the Tap is connected to power. An off power LED indicates that the corresponding power supply is not functioning or not connected.

Application Diagram

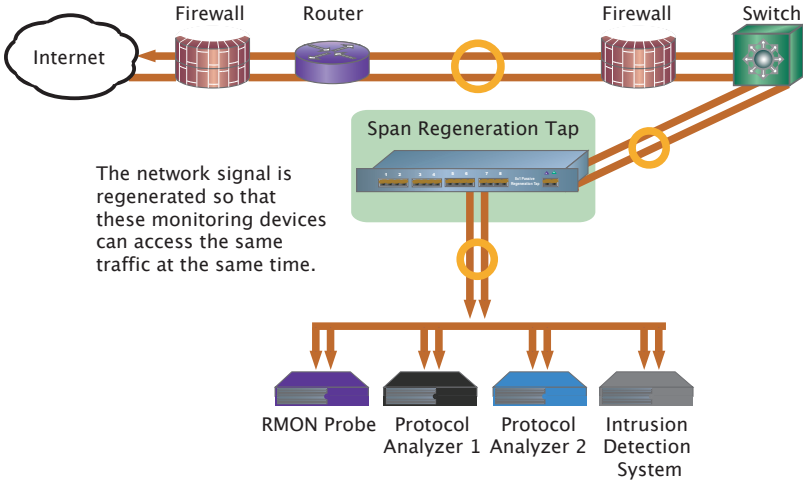

Figure 5: 8x1 GigaBit Copper Span Regeneration Tap

Unpacking and Inspection

Carefully unpack the GigaBit Copper Span Regeneration Tap and check for damaged or missing parts. The Tap ships with the following:

- GigaBit Copper Span Regeneration Tap
- Two power cords
- GigaBit Copper Span Regeneration Tap User Guide
- Pads for surface mounting

You may have also ordered an extended warranty. Carefully check the packing slip against parts received. If any part is missing or damaged, contact Net Optics' Customer Service immediately.

About this Guide

This Guide provides you all the information you need to configure and operate the GigaBit Copper Span Regeneration Tap. Please read the entire Guide before attempting to install or operate the Tap.

Connecting to the Span Ports

Span Port Regeneration Taps allow customers to passively monitor two Network Switch Span Ports independent of each other. For example, if a Span session is connected into Network A port, data can be monitored simultaneously on all Monitor A Ports. A second Span session can be connected into Network B port and data can be monitored simultaneously on all Monitor B ports. The data on Network Ports A and B will remain separate data streams at all times.

To connect the Regeneration Tap to switch Span Ports:

1. Connect Network Port A to the appropriate switch Span port using a CAT5e RJ45 cable.
2. Connect Network Port B to the appropriate switch Span port using a CAT5e RJ45 cable.
3. Check the RJ45 connector LEDs to verify that the Regeneration Tap is receiving traffic from the Span ports.

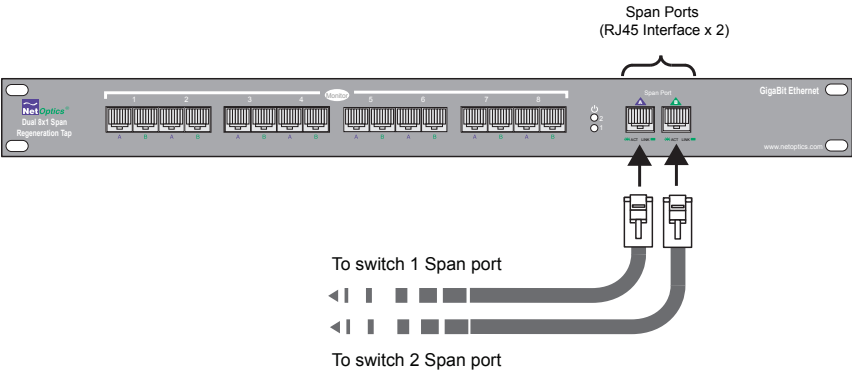

Figure 6: Connecting Span Ports

Connecting to the Monitoring Devices

1. Connect Monitor A ports to the appropriate monitoring devices using a CAT5e RJ45 cable. These devices will monitor Span port traffic from Span A port.

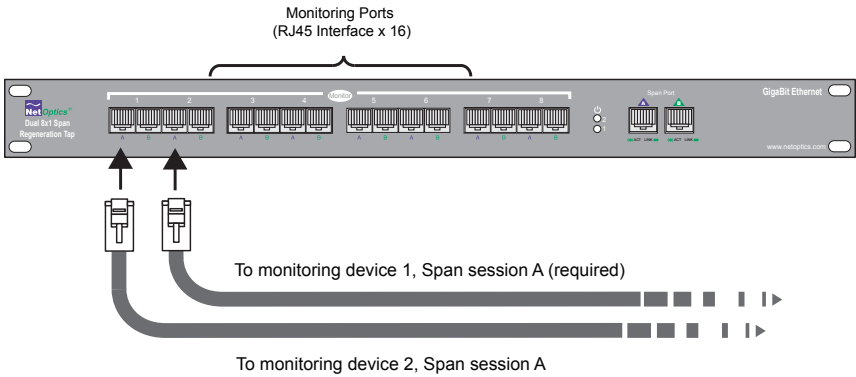

Figure 7: Connecting Monitors to Span Session A

Note:

Monitor 1A port must be connected to a monitor device to establish communications for the rest of the monitor ports.

2. To monitor a second Span port link, connect Monitor B ports to the appropriate monitoring devices using a CAT5e RJ45 cable. These devices will monitor Span port traffic from Span B port.

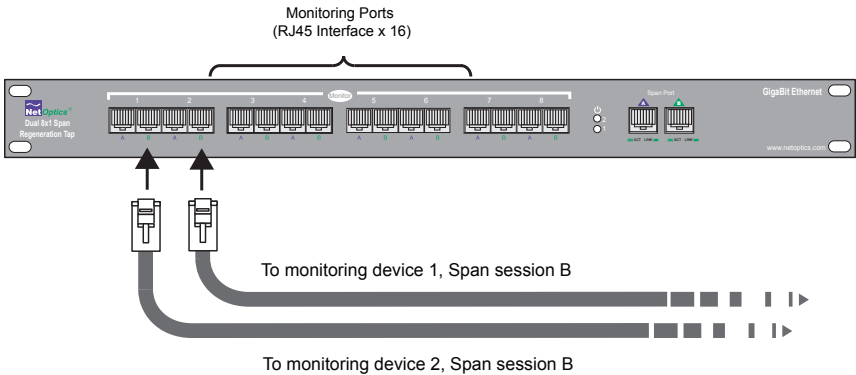

Figure 8: Connecting Monitors to Span Session B

Specifications

Operating Specifications:

Operating Temperature: 0°C to 55°C

Storage Temperature: -10°C to 70°C

Relative Humidity: 10% min, 95% max, non-condensing

Electrical Specifications:

Redundant Power Supplies:

Input: 100-240VAC, 0.5A, 47-63Hz

Input: -48 V DC typical

-36 V DC min, -75 V DC max

Mechanical Specifications:

Dimensions: 1.75" high x 10.5" deep x 17" wide

Cable Interface:

Copper Cable Type: 22-24 AWG unshielded twisted pair cable, CAT5e

Link Distance Supported: 100 meters

Certifications:

Fully RoHS compliant

Connectors:

(2) RJ45, 8-pin connectors (Span ports)

(16) RJ45, 8-pin connectors (RGN-GCU-S8 monitor ports)

(8) RJ45, 8-pin connectors (RGN-GCU-S4 monitor ports)

(4) RJ45, 8-pin connectors (RGN-GCU-S2 monitor ports)

Limitations on Warranty and Liability

Net Optics offers a limited warranty for all its products. IN NO EVENT SHALL NET OPTICS, INC. BE LIABLE FOR ANY DAMAGES INCURRED BY THE USE OF THE PRODUCTS (INCLUDING BOTH HARDWARE AND SOFTWARE) DESCRIBED IN THIS MANUAL, OR BY ANY DEFECT OR INACCURACY IN THIS MANUAL ITSELF. THIS INCLUDES BUT IS NOT LIMITED TO LOST PROFITS, LOST SAVINGS, AND ANY INCIDENTAL OR CONSEQUENTIAL DAMAGES ARISING FROM THE USE OR INABILITY TO USE THIS PRODUCT, even if Net Optics has been advised of the possibility of such damages. Some states do not allow the exclusion or limitation of implied warranties or liability for incidental or consequential damages, so the above limitation or exclusion may not apply to you.

Net Optics, Inc. warrants this Regeneration Tap to be in good working order for a period of one year from the date of purchase from Net Optics or an authorized Net Optics reseller.

Should the unit fail anytime during the said one year period, Net Optics will, at its discretion, repair or replace the product. This warranty is limited to defects in workmanship and materials and does not cover damage from accident, disaster, misuse, abuse or unauthorized modifications.

If you have a problem and require service, please call the number listed at the end of this section and speak with our technical service personnel. They may provide you with an RMA number, which must accompany any returned product. Return the product in its original shipping container (or equivalent) insured and with proof of purchase.

THE WARRANTY AND REMEDIES SET FORTH ABOVE ARE EXCLUSIVE AND IN LIEU OF ALL OTHERS, EXPRESS OR IMPLIED. No Net Optics reseller, agent, or employee is authorized to make any modification, extension, or addition to this warranty.

Net Optics is always open to any comments or suggestions you may have about its products and/or this manual.

Send correspondence to
Net Optics, Inc.
5303 Betsy Ross Drive
Santa Clara, CA 95054 USA
Telephone: +1 (408) 737-7777
Fax: +1 (408) 745-7719
Email: info@netoptics.com/[Internet: www.netoptics.com](http://www.netoptics.com)

All Rights Reserved. Printed in the U.S.A. No part of this publication may be reproduced, transmitted, transcribed, stored in a retrieval system, or translated into any language or computer language, in any form, by any means, without prior written consent of Net Optics, Inc., with the following exceptions: Any person is authorized to store documentation on a single computer for personal use only and that the documentation contains Net Optics' copyright notice.

www.netoptics.com