

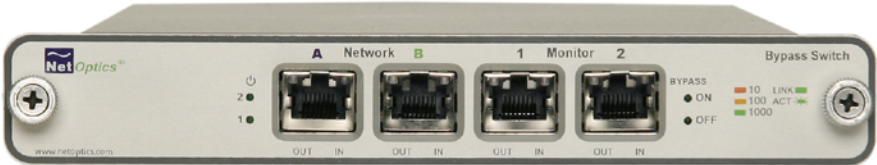

Installation Guide for 10/100/1000 Bypass Switch with Heartbeat™



Contents

Introduction	1
Key Features	2
Product Diagrams	3
LED Functions	3
Bypass Modes	4
Power Loss Bypass	5
Heartbeat Bypass	5
Unpacking and Inspection.	7
Configuring the Bypass Switch.	7
Connecting to the Network.	11
Connecting to the In-line Device	13
Specifications	14
Limitations on Warranty and Liability	15

PLEASE READ THESE LEGAL NOTICES CAREFULLY.

By using a Net Optics 10/100/1000 Bypass Switch you agree to the terms and conditions of usage set forth by Net Optics, Inc.

No licenses, express or implied, are granted with respect to any of the technology described in this manual. Net Optics retains all intellectual property rights associated with the technology described in this manual. This manual is intended to assist with installing Net Optics products into your network.

Trademarks and Copyrights

© 2007 by Net Optics, Inc. Net Optics® is a registered trademark of Net Optics, Inc. Additional company and product names may be trademarks or registered trademarks of the individual companies and are respectfully acknowledged.

Additional Information

Net Optics, Inc. reserves the right to make changes in specifications and other information contained in this document without prior notice. Every effort has been made to ensure that the information in this document is accurate.

Introduction

Net Optics 10/100/1000 Bypass Switches with Heartbeat™ provide permanent and trouble-free access ports for in-line network security and monitoring devices. The Bypass Switch automatically switches network traffic through added in-line devices or bypasses devices that are about to be removed. With a heartbeat, the 10/100/1000 Bypass Switch protects network traffic against link, application, and power loss on the attached in-line device.

Link Fault Protection

The 10/100/1000 Bypass Switch with Heartbeat monitors the link to the attached in-line device by sending a heartbeat packet to the device once every second. If the Bypass Switch does not receive the heartbeat back, Fast Path™ switching automatically diverts network traffic to bypass the unresponsive device—even if the device is still receiving power. The Bypass Switch continues to send the heartbeat and restores the traffic through the in-line device as soon as the link is restored.

Uninterrupted Traffic

The 10/100/1000 Bypass Switch supports fail-safe monitoring with any 10/100/1000BaseT in-line device when it shares the same power source as the in-line appliance. While the Bypass Switch is receiving power, it diverts network traffic to attached in-line devices. In this state, all in-line traffic is routed directly to the device connected to the Bypass Switch.

When the 10/100/1000 Bypass Switch loses power, in-line traffic continues to flow through the network link, but is no longer routed through the device. This allows the network devices to be removed and replaced without network downtime. Once power is restored to the Bypass Switch, network traffic is seamlessly diverted to the in-line device, allowing it to resume its critical functions.

Link Fault Detect™

For superior reliability, the Bypass Switch features Link Fault Detect which gives the devices connected to the Tap critical information about link status. If either side of the bi-directional link fails, the Tap immediately communicates the fault to both devices, reducing the time required to activate a redundant path.

Simply Plug It In

Each 10/100/1000 Bypass Switch includes all the cables and power supplies necessary to connect to an IPS. Three quick steps are all it takes to establish a secure connection point for in-line devices. For special applications, the bypass trigger, heartbeat rate, and heartbeat packet can be customized from an RS232 command line interface.

Key Features

Passive, Secure Technology

- Fail-safe monitoring with any 10/100/1000 GigaBit in-line appliance at speeds up to 1000 Mbps.
- Increased reliability on critical network links.
- High-speed Fast Path™ switching with minimal traffic interruption.
- Customizable settings via command line interface
- Fully RoHS compliant

Ease of Use

- LED indicators show power, speed, link, and activity status
- Front-mounted connectors support easy installation and operation
- Cables included for plug-and-play deployment
- Silk-screened application diagram illustrates all connections for easy deployment
- Optional 19-inch rack frames holds two Bypass Switches
- Tested and compatible with all major manufacturers' monitoring devices, including protocol analyzers, probes, and intrusion detection/prevention systems

Support

- Net Optics offers free technical support throughout the lifetime of your purchase. Our technical support team is available from 8 am to 5 pm Pacific Time, Monday through Friday at +1 (408) 737-7777 and via email at ts-support@netoptics.com. FAQs are also available on Net Optics website at www.netoptics.com.

Product Diagrams

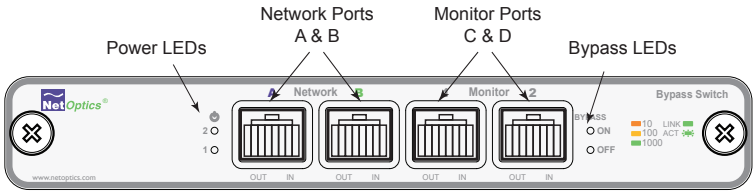

Figure 1: Front Panel

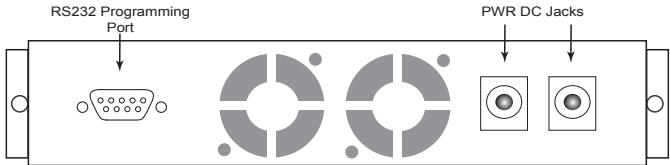

Figure 2: Rear Panel

LED Indicators

- **PWR 1/ PWR 2:** Main and Redundant Power. If the Bypass switch is deployed with both power supplies, both LEDs illuminate green when power is connected to the bypass switch. An off power LED indicates that the corresponding power supply is not functioning or not connected.
- **10/100/1000 Indicator:** Located in the upper left-hand corner of the RJ45 connectors. If the Port is set to 10 Mbps, the LED illuminates orange. If the Port is set to 100 Mbps, the LED illuminates yellow. If the Port is set to 1000 Mbps, the LED illuminates green.
- **Link/Activity Indicator:** Located in the upper right-hand corner of the RJ45 connectors. If a good link is established, the LED illuminates a steady green. When there is current activity on a good link, then the LED flashes.

Bypass Modes

The 10/100/1000 Bypass Switch with Heartbeat bypasses the attached in-line device when one of three events occurs:

- Power loss to the switch
- Link failure
- Application failure

Two LEDs on the front of the 10/100/1000 Bypass Switch indicate whether the bypass switch is bypassing the connected appliance or not. When the Bypass ON indicator is illuminated, the bypass switch has not received the heartbeat packet as expected. When the Bypass OFF indicator is illuminated, the bypass switch is sending traffic through the attached in-line device.

When the bypass switch is in Bypass Enabled (ON) mode, the switch circuitry re-directs network traffic around the in-line appliance. In Bypass Enabled mode Network Ports A and B are connected (see Figure 3).

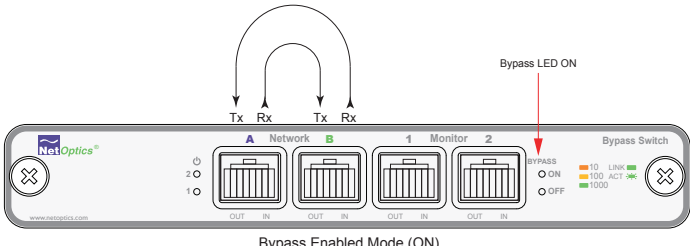

Figure 3: Bypass Enabled

When the bypass switch is in Bypass Disabled (OFF) mode, the bypass switch circuitry sends network traffic through the in-line appliance. In Bypass Disabled mode, Network Port A is connected to Monitor Port C and Network Port B is connected to Monitor Port D (see Figure 4).

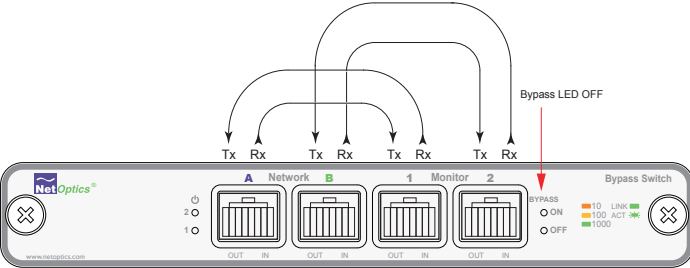

Figure 4: Bypass Disabled

Power Loss Bypass

The 10/100/1000 Bypass Switch protects link integrity when the attached in-line device loses power. To install the 10/100/1000 Bypass Switch for this type of protection, the switch should share the same power source as the in-line appliance. If you are using redundant power supplies for the switch, make sure that both are connected to the same power source as the in-line device.

Heartbeat Bypass

The 10/100/1000 Bypass Switch with Heartbeat protects against both physical link failure and application failure on the in-line appliance. The switch checks the path through the in-line appliance by sending a packet every second from Monitor Port C. The switch validates the path when it receives the packet on the Monitor Port D. If the switch does not receive the packet as expected three times in a row (default setting), the switch automatically enter Bypass Enabled mode. You can change the number of the heartbeat packets required before the bypass switch enters Bypass Enabled mode from the bypass switch CLI (see *Configuring the Bypass Switch* on page 6).

Below is the default heartbeat packet sent once every second from the Monitor Port C. You can change the default timing of the heartbeat packet and the heartbeat packet from the bypass switch CLI (see *Configuring the Bypass Switch* on page 6).

The switch continues to send the heartbeat packet and will return to Bypass Disabled mode as soon as it receives heartbeat packets on Monitor Port D.

The default IPX and IP packets are shown on the following page. Units are shipped from the factory with the IPX packet. When the factory defaults are restored using the "z" CLI command (see "To restore the bypass switch to factory defaults" on page 11), you will be able to select either the IPX or IP packet.

IPX Packet

Packet Contents (Hex) -----	Description -----
00 50 C2 3C 60 00	MAC DA Net Optics
00 50 C2 3C 60 01	MAC SA Net Optics
81 37	Packet Type IPX
FF FF 00 30 00 00 00 00	
40 04 EC A2 C6 13 01 02	
C6 13 01 01 00 00 00 00	
00 00 00 00 00 00 00 00	
00 00 00 00 00 00 00 00	
00 00 00 00 00 00 00 00	
82 A2 BA 71	CRC

IP Packet

Packet Contents (Hex) -----	Description -----
00 50 C2 3C 60 00	MAC DA Net Optics
00 50 C2 3C 60 01	MAC SA Net Optics
08 00	Packet Type IP
45 00 00 3C 18 D2 00 00	
80 01 0A FF 0A 02 01 DC	
0A 01 01 12 08 00 37 5C	
02 00 14 00 61 62 63 64	
65 66 67 68 69 6A 6B 6C	
6D 6E 6F 70 71 72 73 74	
75 76 77 61 62 63 64 65	
66 67 68 69	
B8 8E 1C A9	CRC

Unpacking and Inspection

Unpack the 10/100/1000 Bypass Switch, power supplies, and cables provided. Each 10/100/1000 Bypass Switch is delivered with the following:

- 2 power supplies/cords
- 1 DB-9 programming cable
- 2 CAT5e network cables (1 cross-over, 1 straight-through)
- 2 CAT5e monitor cables (straight-through)
- 1 Installation Guide

You may have also purchased a panel for rack mounting the bypass switch and an extended warranty. If any component is missing or damaged, contact Net Optics Customer Service immediately.

Configuring the Bypass Switch

The 10/100/1000 Bypass Switch allows you to set several configuration options and to display configuration information. You can set:

The frequency of the heartbeat.

This defines the period of time that passes before the switch considers the packet to have timed out. The default is 1 second.

The number of timeouts allowed.

This is the number of packets missed before the switch bypasses the IPS (retry count). The default is 3 missed packets.

Port communication parameters.

You can set the ports for fixed speed or auto-negotiation and full- or half-duplex communications. You also turn Link Fault Detect and Bypass Detect on or off. The default is LFD and Bypass Detect on.

A custom heartbeat packet.

You can input a custom heartbeat packet to suit special needs. The default is the IPX packet shown on page 5.

Reset to factory defaults.

Use this option to quickly restore the original configuration.

For quick reference, you can display the configuration settings and heartbeat packet.

Link Fault Detect

You can set the bypass switch to drop the remaining full-duplex link when one side fails. The Link Fault Detect features ensures that connected devices are aware of a failure on both sides of the link.

Bypass Detect

You can set the Monitor Ports to cycle on and off while the bypass switch is in Bypass Enabled mode. In Bypass Detect mode, the Monitor Ports cycle through five seconds off followed by ten seconds on. The alternating link status can be used to trigger attached devices to send an alarm to a management system every time the bypass switch turns off the Monitor Ports. When the bypass switch returns to Bypass Disabled mode, the Monitor Ports remain on and the on/off cycle is discontinued.

Note:

Before starting, make sure power to the bypass switch is disconnected.

To access the bypass switch CLI:

1. Using the RS232 DB-9 cable provided, connect a PC running terminal emulation software, such as HyperTerminal, to the RS232 port on the rear panel of the bypass switch.

2. Set the terminal emulation software to the following communication parameters:

- 9600 baud
- 8 data bit
- No parity
- 1 stop bit
- No flow control

3. Connect power to the bypass switch. The software compile date and time is displayed in the terminal emulation software as shown in the example below.

```
Compiled on 16-Jan-06    15:35:00
Type ? for a list of commands
```

4. Type ? and press Enter for a list of commands.

The following commands are listed:

- a = Input Timeouts
- b = Input Configuration
- c = Input Heartbeat Packet
- d = Display Configuration
- e = Display Heartbeat Packet
- z = Reset to Factory Defaults

To set the timeout values:

1. Type a and press Enter to set the timeout values.
2. At the `input time out period` prompt, enter the number of seconds between each heartbeat (1-254 seconds). Press Enter.
3. At the `input retry count` prompt, enter the number of missed heartbeats allowed before the switch enters Bypass ON mode (1-254). The input retry count must be greater than or equal to the input timeout. Press Enter.

Note:

Manufacturing default for Input Timeout Period and Input Retry Count are set to 1 and 3 respectively.

To set the communications parameters:

1. Type b and press Enter.
2. At the `Auto neg on/off` prompt, type **1** to turn on or **0** to turn off auto-negotiation.
3. At the `1 Gig on/off` prompt, type **1** to turn on or **0** to turn off 1 Giga-Bit line speed.
4. At the `100 Mbs on/off` prompt, type **1** to turn on or **0** to turn off 100 Mbps line speed.
5. At the `10 Mbs on/off` prompt, type **1** to turn on or **0** to turn off 10 Mbps line speed.
6. At the `Full Duplex on/off` prompt, type **1** to turn on or **0** to turn off full duplex.

Note:

All ports must be set to the same speed and duplex parameters.

7. At the `Bypass Detect on/off` prompt, type **1** to turn on or **0** to turn off Bypass Detect.
8. At the `LFD on/off` prompt, **1** to turn on or **0** to turn off Link Fault Detect.

To input a custom heartbeat packet:

1. Type `c` and press Enter. You are prompted for the length of the packet including header bytes and CRC bytes.
2. Enter the length of your custom packet in decimal format and press Enter. You are prompted for each packet byte.
3. Enter packet bytes in Hex format in the following order:

MAC DA Net Optics (6 bytes)
MAC SA Net Optics (6 bytes)
Packet Type (2 bytes)
Packet Bytes
CRC (4 bytes)

Alternately you can load the packet as a pre-formatted text file. The text file must be one byte per line beginning with a decimal value for the number of packets followed by hex values for the remaining bytes. Load the text file at the packet length prompt.

To load a packet from a file, you must set the Line Delay to 1000 milliseconds and the Character Delay to 100 milliseconds in your terminal emulation software. If you are using HyperTerminal, these settings are located in the ASCII Setup dialog box found in File>Properties>Settings>ASCII Setup.

To display the current values:

1. Type `d` and press Enter. A list similar to the following appears.

```
input timeout period 1
input retry count 3
port setting gigabit
```

```
duplex full
LFD on
Bypass Detect on
Bypass Disabled
```

To display the current packet:

1. Type e and press Enter. The packet is displayed as shown in the example below.

```
packet length = 78
MAC DA 00 50 c2 3c 60 00
MAC SA 00 50 c2 3c 60 01
Packet Type 08 00
45 00 00 3c 18 d2 00 00
80 01 0a ff 0a 02 01 dc
0a 01 01 12 08 00 37 5c
02 00 14 00 61 62 63 64
65 66 67 68 69 6a 6b 6c
6d 6e 6f 70 71 72 73 74
75 76 77 61 62 63 64 65
66 67 68 69
CRC bb 8e 1c a9
```

To restore the bypass switch to factory defaults:

1. Type z and press Enter. You are prompted to select which type of packet you want to restore, IP or IPX.
2. Select 1 to restore defaults with an IP packet or 0 to restore defaults with an IPX packet.

The bypass switch will be reset to the following defaults:

```
Input Timeout Period: 1
Input Retry Count: 3
Port Speed Gigabit
Full Duplex
LFD: On
Bypass Detect: On
Heartbeat Packet: IPX
```

Connecting to the Network

1. Connect Network Port A to the appropriate switch, server or router device using a straight-through cable.
2. Connect Network Port B to the appropriate switch, server or router device using a cross-over cable.
3. Verify that the bypass switch Network Ports are cabled in-line between two devices.

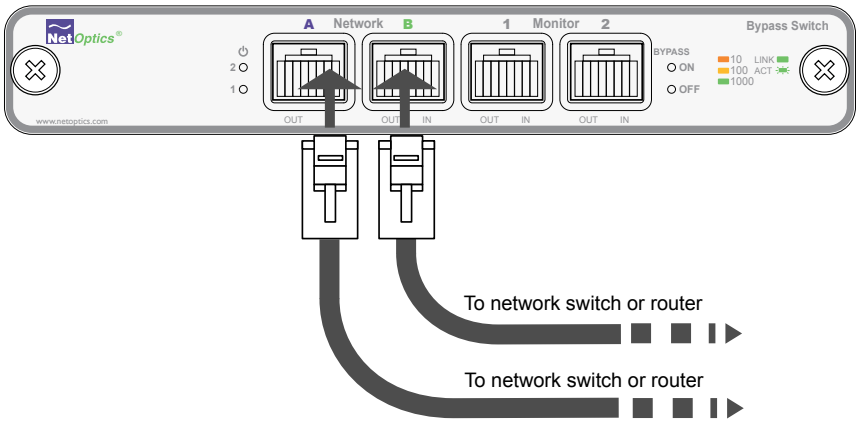

Figure 5: Connecting the Network Ports

Connecting to the In-line Device

1. Connect Monitoring Port C to the in-line device using a CAT5 RJ45 straight through cable.
2. Connect Monitoring Port D to the in-line device using a CAT5 RJ45 straight through cable.
3. Verify that the Monitoring Ports are cabled to the in-line device.

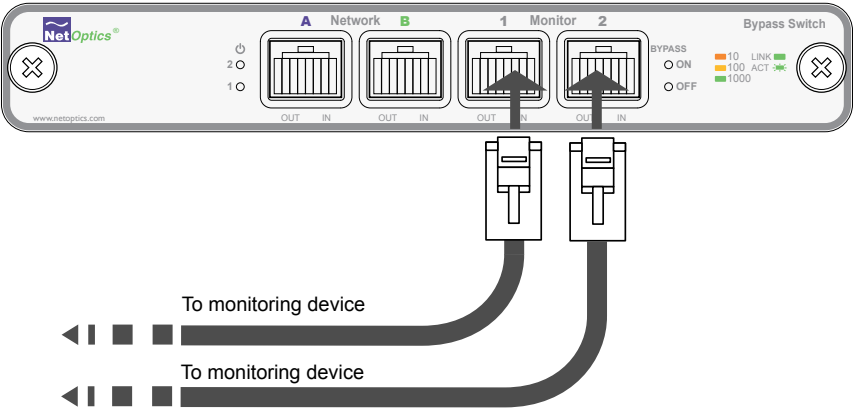

Figure 6: Connecting the Monitor Ports

Specifications

Environment

Operating Temperature: 0°C to 40°C

Storage Temperature: -10°C to 70°C

Relative Humidity: 10% min, 95% max, non condensing

Mechanical

Dimensions: 1.125" high x 10" deep x 6.5" wide

Power

Power Supply Input: 100-240V, 0.5A, 47-63Hz

Power Supply Output: 12V, 3A

Cable Interface

Copper Cable Type: 22-24 AWG unshielded twisted pair cable,
CAT5/CAT5E

Link Distance Supported: 100 meters

Connectors

(2) RJ45, 8-pin connectors (monitoring ports)

(2) RJ45, 8-pin connectors (network ports)

Certifications

Fully RoHS compliant

Limitations on Warranty and Liability

Net Optics offers a limited warranty for all its products. IN NO EVENT SHALL NET OPTICS, INC. BE LIABLE FOR ANY DAMAGES INCURRED BY THE USE OF THE PRODUCTS (INCLUDING BOTH HARDWARE AND SOFTWARE) DESCRIBED IN THIS MANUAL, OR BY ANY DEFECT OR INACCURACY IN THIS MANUAL ITSELF. THIS INCLUDES BUT IS NOT LIMITED TO LOST PROFITS, LOST SAVINGS, AND ANY INCIDENTAL OR CONSEQUENTIAL DAMAGES ARISING FROM THE USE OR INABILITY TO USE THIS PRODUCT, even if Net Optics has been advised of the possibility of such damages. Some states do not allow the exclusion or limitation of implied warranties or liability for incidental or consequential damages, so the above limitation or exclusion may not apply to you.

Net Optics, Inc. warrants this 10/100/1000 Bypass Switch to be in good working order for a period of ONE YEAR from the date of purchase from Net Optics or an authorized Net Optics reseller.

Should the unit fail anytime during the said ONE YEAR period, Net Optics will, at its discretion, repair or replace the product. This warranty is limited to defects in workmanship and materials and does not cover damage from accident, disaster, misuse, abuse or unauthorized modifications.

If you have a problem and require service, please call the number listed at the end of this section and speak with our technical service personnel. They may provide you with an RMA number, which must accompany any returned product. Return the product in its original shipping container (or equivalent) insured and with proof of purchase.

Additional Information

Net Optics, Inc. reserves the right to make changes in specifications and other information contained in this document without prior notice. Every effort has been made to ensure that the information in this document is accurate. Net Optics is not responsible for typographical errors.

THE WARRANTY AND REMEDIES SET FORTH ABOVE ARE EXCLUSIVE AND IN LIEU OF ALL OTHERS, EXPRESS OR IMPLIED. No Net Optics reseller, agent, or employee is authorized to make any modification, extension, or addition to this warranty.

Net Optics is always open to any comments or suggestions you may have about its products and/or this manual.

Send correspondence to
Net Optics, Inc.
5303 Betsy Ross Drive
Santa Clara, CA 95054 USA
Telephone: +1 (408) 737-7777
Fax: +1 (408) 745-7719
Email: info@netoptics.com/[Internet: www.netoptics.com](http://Internet:www.netoptics.com)

All Rights Reserved. Printed in the U.S.A. No part of this publication may be reproduced, transmitted, transcribed, stored in a retrieval system, or translated into any language or computer language, in any form, by any means, without prior written consent of Net Optics, Inc., with the following exceptions: Any person is authorized to store documentation on a single computer for personal use only and that the documentation contains Net Optics' copyright notice.

www.netoptics.com